

The LabelMax90 Labeling System is a compact and economically-priced in-line label applicator that is ideal for production rates of up to 90 containers per minute. Featuring a programmable microprocessor that manages specific functions of the operation. Computerized controls are simple and dependable and allow the operator to match speeds of the labeler to the pre-set conveyor speed.

Optical sensors ensure a smooth and trouble-free operation. The front panel display provides real-time information on the labeling process. The unit's simplicity makes it ideal for packaging lines requiring frequent changeovers on a wide variety of products. An optional clear label sensor is available for applying clear labels.

## Quickly Label a Variety of Containers

- Operation speed is adjustable to a wide range of round container sizes

## Premium Features

- Advanced Stepper Motor and quality Optical Sensor make operations quick, precise, and reliable
- Complete with automatic warning-feature for label breaks, empty spool, and low label volume

## Built to Last

- Conveyor-mounted assembly
- Lightweight, rigid construction for long-lasting operation

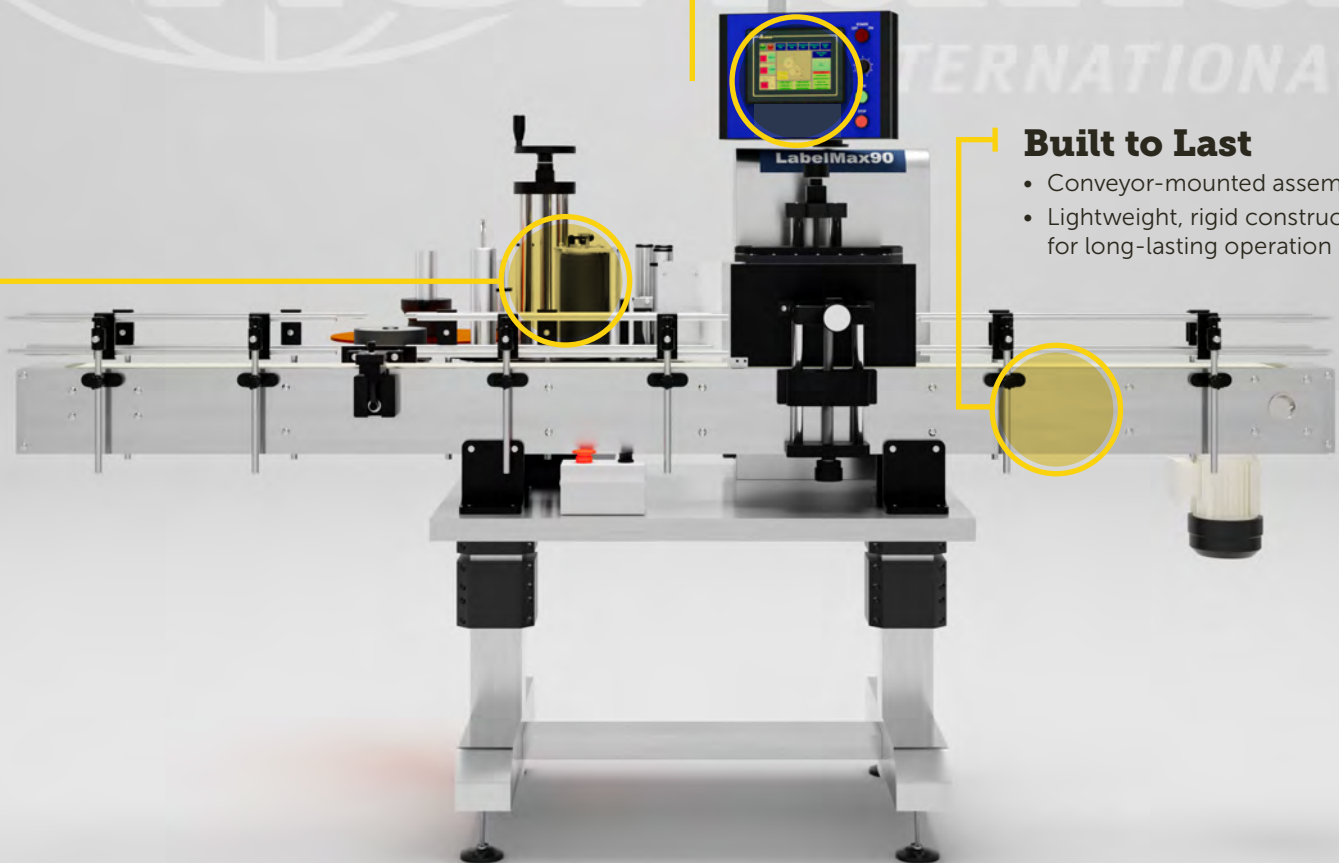

# LabelMax90

## Labeling Specifications

- Container diameter: 2 in-6 in (51 mm-153 mm)
- Container height: 5 in-12 in (127 mm-304 mm)
- Label width: 2.5 in-6 in (64 mm-153 mm)
- Label length: 2.5 in-11.75 in (64 mm-299 mm)
- Label position on container = .25 in (6.35 mm) less than label panel of the container
- Length of label on container = .25 in (6.35 mm) less than container circumference
- Unwind orientation: #3 or #4. Customer must specify
- Label placement – label must be at least 1.5 in (38 mm) and no more than 5.25 in (133 mm) from the bottom of the container
- Label gap: .125 in (3.175 mm)
- Width of base paper = label width + .156 in (3.98 mm)
- Face stock: non-transparent standard
- Maximum spool diameter = 14 in (355.6 mm)
- Core diameter: 3 in (76 mm)
- Wrap around alignment:  $\pm .125$  in ( $\pm 3.175$  mm)

## Your Complete Package

Each LabelMax90 that leaves our facility carries UL certification and an industry-leading five year limited warranty on the metal and welds. In addition to a comprehensive spare parts inventory, you'll receive superior customer support from our team in Lincoln, Nebraska with any Norland purchase.

## Compatible Products

- CraftCan Canning Systems
- TruPatriot Bottle Filler
- Autopak Can Carrier Applicator

